



In this issue: • 2017 Continental HUD Calibration • ADAS and Windshields • Sikkens Color Matching  
• Rivet-Bonding Techniques • Inside the Industry • F-150 Water/Dust Kit

## Ford Begins Roll-Out of 2019 Ranger Info



The adventure-ready, all-new 2019 Ford Ranger brings Built Ford Tough capability and innovation to America's midsize truck segment. Developed and tested to Ford's demanding standards, the Ranger shares a heritage of toughness, durability and capability derived from the company's relentless focus on engineering excellence in building award-winning trucks for over 100 years.

Here are some introductory details on the 2019 Ranger—expected in showrooms in early 2019 in XL, XLT and Lariat trim levels— followed by valuable information on its all-new high-strength steel frame:

- Fully boxed high-strength steel frame
- Frame-mounted front and rear steel bumpers
- Double-wishbone suspension, monotube shocks
- Parabolic rear leaf springs
- Designed, engineered and tested to F-150 standards
- Advanced driver-assist and connectivity technologies
- Available FX4 Off-Road Package
- Powerful and versatile 2.3-liter EcoBoost® engine
- Class-exclusive 10-speed automatic transmission
- Available Terrain Management System™ and Trail Control™

- Wide approach and departure angles
- Steel front bash-plate<sup>(1)</sup> and underbody skid plates (4x4 only)
- Electronic shift-on-the-fly transfer case<sup>(2)</sup> (4x4 only)
- Dana® AdvanTEK® independent front and solid rear axles with optional electronic-locking rear axle<sup>(3)</sup>

### Innovative Technology

Automatic Emergency Braking comes standard across the Ranger lineup. Lane Keeping Assist, Lane Departure Warning, Reverse Sensing System and class-exclusive Blind Spot Information System with trailer coverage are standard on XLT and Lariat, while Pedestrian Detection and Adaptive Cruise Control are standard on Lariat.

(1) FX4 Off-Road Package models only.

(2) Speed limitations apply. See owner's manual for complete details.

(3) Dana independent front axle available on 4WD models only.

## 2019 Ranger: All-New High-Strength Steel Frame



### Ford Senior Damageability Engineer Gerry Bonanni discusses key aspects of the new truck's frame and what it offers to repairers

As Ford readies the all-new 2019 Ranger for its debut, the mid-size truck will feature little in relation to the previous version—discontinued in 2011—other than its name. Not only will the new truck be packed with innovative technology, it is also designed, engineered and tested to the demanding standards of the F-150, and will feature an all-new, fully-boxed high-strength steel frame.

"The new Ranger is a neat truck," said Bonanni. "Especially with what it offers as separately serviceable parts for repairers, including in its new frame."

"The frame on the 2019 Ranger offers an incredibly strong, versatile foundation – one usually found on much larger trucks," said

Bonanni. "It's like a mini-F-150 frame that incorporates Super Duty [frame] elements as well."

Bonanni noted that the frame will have several separately serviceable elements, including numerous frame-sectioning kits, crossmembers, lower control arm brackets, additional bracketry [kits] and other components.

In terms of frame-sectioning kits, Bonanni revealed that the new Ranger will offer repairers several options to fit their individual repair plans and the specific damage that might be found on the truck. The frame-sectioning kits include the usual front- and rear-third, but also include a shorter, front-stub section, as well as a rear-most sectioning kit to address the back of the truck. All frame-sectioning options are designed to help technicians when repairing damage caused by front-end or rear-end collisions. Only a small section of the center-most area of the frame is not separately serviceable, and damage to that area would require frame replacement.

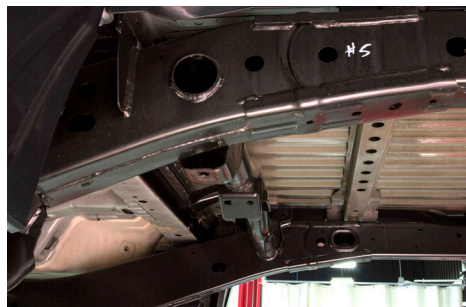

Another new design element is the addition of front-most crossmembers. "The inclusion of these front crossmembers is significant," said

Bonanni. "They add an incredible amount of strength up front, where we noted previous, extensive damage. The new crossmembers and their placement help to greatly mitigate the forces involved in a head-on collision, helping prevent intrusion into the front of the vehicle and hopefully saving what otherwise might have been a total loss."



He also highlighted the location of the crossmembers in the middle and rear of the vehicle, noting that they cut through the fully-boxed frame, and are perimeter-welded on both the inside and outside of the frame as well. "Having the crossmembers pierce through the frame provides an incredible amount of rigidity," Bonanni concluded. "It's a very robust design."

Additional repair-specific information on the 2019 Ranger is planned for future editions of *On Target*, as it becomes available.

For repair questions on the Ranger, or any Ford or Lincoln vehicle, contact Gerry Bonanni at (313) 317-9000 or the Ford Crash Parts Hotline: [cphehelp@fordcrashparts.com](mailto:cphehelp@fordcrashparts.com).

## Techniques for Rivet-Bonding Aluminum Vehicles (Part 1)



*Courtesy of Douglas Craig, Technical Application Engineer & Collision Industry Liaison, Structural Adhesives Tech Service, LORD Corporation*

By now, many technicians are seeing damaged aluminum-bodied vehicles coming into the shop. However, the usual repair techniques used to repair the “typical” steel-bodied vehicle are no longer appropriate. Aluminum panels cannot be successfully resistance (“spot”) welded in a shop setting, so rivet bonding is the preferred repair method. While rivet bonding is a relatively simple procedure, it is crucial for the repair technician to understand how to use the rivets and the adhesives to perform a successful repair.

### Welding vs. Rivet Bonding

At the OEM level, spot welding of aluminum is possible, but it is fraught with challenges. Power requirements for aluminum welding are about three times higher than for steel. Aluminum conducts heat much faster than steel, so more heat is required to reach the proper weld temperature (see warning on aluminum heat transference on page 4). Welding weakens aluminum due to the heat’s effect on the basic metallurgy of the material. Aluminum can become very brittle when welded and is prone to cracking even before the weld is completed.

In addition, the oxide layer on aluminum increases welding difficulties. Bare aluminum is coated with an oxide layer that acts as a protectant for the material. This oxide layer is extremely hard, making it difficult to penetrate and perform an effective weld.

Aluminum welding requires highly specialized

weld units and procedures (pre-heating and post-heating), along with a slow cool down, that make it unfeasible for the average repair shop. The challenges of aluminum welding, which are complicated even for OEMs, have made mechanical fastening (rivet bonding) a quicker, easier solution. With rivet bonding, welding heat is eliminated from the joining procedure, and the rivets deliver such a tight fit that it is impossible for corrosion to occur.

### “New?” Rivet Bonding

With the advent of aluminum and composites as substrates in vehicle manufacturing, rivet bonding will be a new procedure for many repair shops. As a fastening method though, rivets are not new, as they have been in use for more than 60 years in the aerospace industry. Aircraft, which are mostly made of aluminum, feature rivet fasteners everywhere, inside and outside.

To perform a successful repair, the technician must know the rivet style specified by the OEM and the adhesive recommended by the OEM, and also use the proper tooling for installing the different rivets. Always follow OEM guidelines for choosing which rivets and adhesives to use when making vehicle repairs. Any deviation from the OEM procedures can result in a failed repair, additional work and customer dissatisfaction.

### Rivets and Tooling

Repair technicians should familiarize themselves with the three basic types of rivets used on most aluminum vehicles: pull-style, self-piercing and flow-form rivets.

- *Pull-style rivets* are structural rivets. They are extremely strong, feature a mechanical lock and break close-to-flush with the rivet head. To install a pull-style rivet, drill a hole in the panel, insert the rivet, and with the appropriate tooling, pull the metal shank to crush the rivet.
- *Self-piercing rivets (SPRs)* are pushed into the metal panel with a specialized tool; no pre-drilling is needed. An SPR cuts its own hole and creates a mechanical lock within the material.
- *Flow-form rivets* are used extensively in the construction industry, especially for building high-rise structures. They are now available in a small-scale version for vehicle repair. To install a

flow-form rivet, punch a hole in the panel, apply adhesive, insert the rivet and press the panels together.

For the most part, each type of rivet requires its own installation tooling. If the proper tooling is not used, the workpiece could be distorted, or not enough clamping force will be delivered to successfully install the rivet. Specific installation tools for each type of rivet are available.

### Rivets and Adhesives

When beginning a repair, it is important to make sure you are using the right rivet for that repair. First, check the OEM recommendation for the rivet part number, and then order the rivets per repair. Each type of rivet is classified by the OEM for grip range, coating and strength, with part numbers indicated for repair rivets.

In the rivet bonding process, adhesives provide strength, corrosion protection and sealing. As with rivets, it’s important to use the adhesive recommended by the OEM for the repair procedure. Though OEMs might use several different types of adhesives in vehicle manufacturing, they will usually specify only one type of repair adhesive. The choice of adhesive depends on the function of the joint in the vehicle.

For rivet bonding, the OEM will be specifying a structural adhesive or the next level up—a crash-durable or impact-resistant adhesive. Two-component crash-durable adhesives can be used to replace all OEM one-component, crash-durable adhesives. These “impact-toughened” adhesives offer the strength of structural adhesives combined with excellent flexibility.

This property is especially important when joining thinner substrates, such as aluminum, where the extra flexibility helps to hold the joints together in crash mode.

Stay tuned for the next issue of *On Target* for the continuation of this series, which will include additional helpful guidelines.

For more information on rivet-bonding repairs as it directly relates to Ford and Lincoln vehicles, please contact Gerry Bonanni at (313) 317-9000 or the Ford Crash Parts Hotline at [cphep@fordcrashparts.com](mailto:cphep@fordcrashparts.com).

## 2019 F-150 Limited: Most Powerful, Advanced F-150 Ever



Ford Motor Company—America’s truck leader—is now offering Ford pickup fans the power of the Ford Raptor in an upscale package, with the new 2019 F-150 Limited.

Featuring a new, high-output 3.5-liter EcoBoost® V6 engine and rated at 450 horsepower and 510 lb.-ft. of torque, the F-150 Limited leads the competition, offering more power than any light-duty pickup on the road. The truck also sports a new dual exhaust system with exhaust tips smoothly integrated into new rear bumper cutouts.

An integrated trailer brake controller is standard, as is a 360-degree camera with split-view display and dynamic hitch assist to simplify the hitching process. Class-exclusive Pro Trailer Backup

Assist™ is optional to make maneuvering easier by letting drivers rotate a knob to control its direction, with the truck automatically steering to follow the course selected.

Standard adaptive cruise control with stop-and-go functionality allows drivers to set a cruising speed; radar and camera technology then monitor traffic ahead to maintain a set distance between vehicles—even braking to a complete stop if necessary. In addition, Standard Pre-Collision Assist with Automatic Emergency Braking helps drivers avoid or mitigate collisions with other vehicles and pedestrians.

The F-150 Limited is in showrooms now.



## ADAS: The Importance of a Dimensionally-Correct Windshield

*Provided exclusively to On Target by Ken Pew, FCSD/Carlex Technical Services Manager*

Advanced Driver Assist Systems—more commonly known as ADAS—has become the blanket term to describe the equipment and sensors installed and programmed into a vehicle for assisting drivers with appropriate traffic warnings, and in some cases, they provide actual position adjustments to reduce accidents.

Originally introduced on high-end vehicles, the obvious advantages ADAS features provide have resulted in many automakers making them standard features on their vehicles, including Ford Motor Company.

As these systems become more prolific, their role in completing an approved, proper and safe vehicle repair will continue to grow as well, requiring an awareness of the importance of using OEM replacement glass when one or more of these features interfaces directly with the glass components. Cameras, which may be mounted directly to the windshield or positioned looking through it, are the most common feature.

These cameras—combined with a radar sensor within the vehicle's body panels and front grille—communicate with each other to create a “force field” around the vehicle. These embedded sensors warn drivers of potential accidents.

It's important to know that all sensors are turned on and then “zeroed” to the center of the vehicle during the assembly process, meaning the entire exterior shape of the vehicle—including the glass surface's unique curvature—is crucial in order for the radars, cameras and sensors to “know” where they are in relation to the vehicle exterior. Projecting out from the vehicle, these sensors provide feedback to the onboard software, which communicates with the driver in various ways, starting with an audible alert, and escalating all the way to taking control of the vehicle.

This is important because, while windshields have long been considered a structural part of the vehicle, now more than ever, their dimensional repeatability for both assembly and service is critical to ensure ADAS features operate as intended.

Many glass engineers, already armed with this knowledge, recommend the need for calibration of the cameras after the windshield has been replaced. This process—when completed with OEM glass—will properly reset the new position of the camera as it relates to the “force field” around the car. The vehicle software needs to “know” the new position of the camera; if it is too far away,

feedback to the onboard software may not be correct.

In today's windshield manufacturing process, automakers demand entire surface control and have upwards of 30 to 50 embedded sensors in the final check gauge, with each point rated within +/- 3 sigma of nominal measurement. This provides the confidence that during OEM assembly, the vehicle-to-vehicle variation is kept accurate and repeatable, so there are no interruptions in process flow, while at the same time providing confidence there will be no problems with the initial end-of-line calibration setup.

When installing a new windshield, repairers must understand that not only is its correct placement important—from side-to-side and up-and-down—but the curvature over the entire surface also plays a large role in correct operation and providing accurate feedback to the driver. Repairers should also be careful to avoid any optical distortion from entering the camera zones.

Once the windshield service has been completed properly with the right glass and all calibrations finished, the ADAS features and other benefits should work as intended.

Being well-versed in these and other windshield-related ADAS issues—while making sure to follow all OEM repair procedures—is critically important for repairers to help ensure they deliver a properly repaired vehicle to their customers.

## Ford Releases New Truck Bed Water/Dust Intrusion Kit

Ford Motor Company has released a new accessory kit to help Ford truck customers keep rain, dust and snow out of the beds of their 2015 – 2018 F-150 vehicles.

Building on the previous bed/tailgate dust seal kit (part number VLF3Z-99404A06-A), the new, far more comprehensive kit includes:

- 1 Tailgate dust seal (all-weather EPDM industrial high-grade rubber)
- 1 Motorcraft TA-2 Seam Sealer
- 4 Plugs (bed-extender holes)
- 2 Bolts (bed-extender attachment holes)
- 1 (pair) Plastic plugs for tailgate corner (at hinge)

First, shops should install the tailgate dust seal—which is as simple as peel and stick—after cutting to desired length. Then, add seam sealer along the inner side of the bed floorplan (inside the box side panels) and install the four plugs in the bed-extender holes, located in the D-pillar (two per side).

The next step is to install the two bolts—one per side—in the bed-extender attachment holes, also located within the D-pillar. Finally, snap the two plastic tailgate corner plugs into place.

This completed process will now help to mitigate water and dust intrusion into the truck bed.



**The new kit  
part number  
VJL3Z-99404A06-A  
can be ordered through  
[accessories.ford.com](http://accessories.ford.com).**

## Ford Implements OEConnection's MyPriceLink

Ford has announced it will soon begin using OEConnection's patented MyPriceLink technology to deliver real-time dynamic collision parts list pricing based on timing and local market conditions.

Using a variety of data attributes to determine the appropriate collision part list price at a specific moment in time, MyPriceLink does away with the static price tapes of the past and aims to give Ford dealers a competitive advantage.

“MyPriceLink will aid in protecting our list prices and how they are used in the marketplace, while also providing fast and effective delivery of the dynamic list pricing for the transaction,” said Ford Global Collision Business and Strategy Manager Jennifer Boyer. “MyPriceLink is just one tool we are using to help ensure quality repairs, value and availability of original equipment parts for our customers.”

MyPriceLink will be implemented during the 4th quarter of 2018.

# Ford Details Proper Roof Panel Repair (Part 2 – Installation)

Furthering Ford Motor Company’s effort to ensure repairers are aware of proper repair procedures, Senior Damageability Engineer Gerry Bonanni recently spoke with *On Target* regarding some specifics on Ford-approved methods for roof repair for its vehicles, using the 2015 – 2018 F-150 as an example. In the previous volume (*On Target - 2018, Vol. 2*), the removal of the old roof panel was detailed. Here, Bonanni reviews the process for installing the new panel.

This specific vehicle repair—**Section 501-28: Roof Sheet Metal Repairs, Removal and Installation**—is found in the official Ford Workshop Manual, located on [Motorcraftservice.com](http://Motorcraftservice.com).

“The official Ford procedure in the workshop manual does a good job of walking repairers through the proper process,” said Bonanni. “But, repairers are always reminded to thoroughly research the repair as much as they can before they begin any repairs.”

The repair procedure begins by detailing the tools, equipment and materials needed, including:

- Locking pliers
- Grinder
- Self-piercing rivet (SPR) remover / installer
- Metal bonding adhesive (TA-1, TA-1-B, 3M™ 08115, Lord Fusor® 108B)
- Roof ditch sealer (3M™ 08307, Lord Fusor® 122EZ)

Bonanni also noted that repairers should adequately protect the exterior finish, interior trim and all glass from contamination during the entire repair.

The procedure also includes a message about heat transference when working with aluminum body panels.

*Aluminum body panels are highly receptive to heat transfer. With the extensive use of structural adhesives and non-structural sealers in vehicle construction, the potential of heat transfer could impact adhesives and sealers in non-associated panels during the repair process. Many repair areas that utilize structural adhesives may be separated after fastener removal*

*by using a panel chisel along the joint/flange. Heat not exceeding 425°F may be used to loosen a bonded panel but should only be done when all panels in the joint will be replaced and new adhesive applied.*

## Installation

The last step of the roof panel removal process—as detailed in the previous issue—was to use a grinder or air chisel to carefully remove the remaining portion of the roof panel flange and laser-weld bead, and to avoid thinning the metal in this area.

Using a hammer and dolly dedicated to aluminum repair, repair any damage from the body-side flange to the roof mating surfaces, referring to Section 501-25: Body Repairs – General Information, Description and Operation.

Sand and clean the roof mating surfaces using the grinder. Then, switching to 80-grit sand paper, remove the e-coat and continue to sand and clean.

With the help of an assistant, install the new roof outer panel, and properly align and index-mark it to the vehicle. Once properly aligned, install the new roof panel to the index marks by applying metal-bonding adhesives (TA-1, TA-1-B, 3M™ 08115, Lord Fusor® 108B). (**Figure 1**)

Figure 1

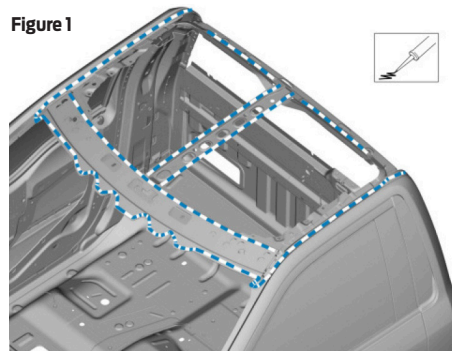

“It is critical that repairers **do not** lift the new roof panel when aligning to the index marks,” cautioned Bonanni. “Instead, repairers should slide the new panel into position. This will reduce the possibility of breaking the adhesive bond.”

The procedure then instructs repairers to:

- Check for full adhesive contact, and to add any additional adhesive to the roof bows, if necessary.
- **Not** remove any excess adhesive that squeezes out in the roof-ditch area. Instead, it should be smoothed into the joint to act as additional sealer.

- Clamp the new panel into position using the locking pliers (once properly aligned and bonded).

The panel is now ready to receive new self-piercing rivet fasteners (SPRs), referring to Section 501-25: Body Repairs – General Information, General Procedures.

“SPR fasteners cannot be placed directly over the original SPR location,” said Bonanni. “They must be placed adjacent to the original location matching the original quantity. Blind or solid rivets may be used in place of SPRs in the original SPR location, but only after it is widened to 6.5 millimeters.” (**Figures 2 & 3**)

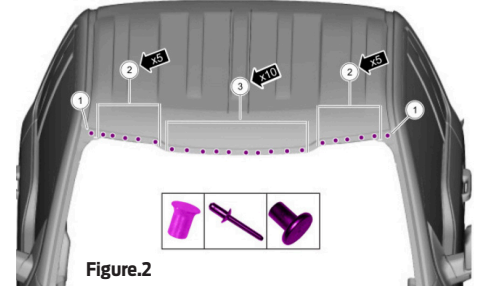

Figure 2

After installing the SPR fasteners, sand and prime the front- and rear-window opening channels using a Ford-approved epoxy-based primer. After masking off the front- and rear-window channels, apply roof ditch sealer (3M™ 08307, Lord Fusor® 122EZ), making sure to carefully follow the manufacturer’s instructions.

Refinish the entire repair area using a Ford-approved paint system and standard refinishing techniques; remove the masking from the front and rear windows. Reinstall the components that were previously removed, including the satellite radio antenna, windshield and rear-window glass, side-curtain airbags and headliner. Be sure to repower the Supplemental Restraint System.

“Each component in today’s vehicles is carefully designed to work together in a complex sequence to ensure proper functionality and safety in the event of a collision,” Bonanni concluded. “Any unauthorized change to any one component or disregarding any step in the repair process can lead to catastrophic results.”

For more information on this or the repair of any Ford or Lincoln vehicle, contact Gerry Bonanni at (313) 317-9000 or the Ford Crash Parts Hotline at: [cphelp@fordcrashparts.com](mailto:cphelp@fordcrashparts.com).

Item	SPR Number	SPR Code	Henrob® Mandrel	Pro-Spot® Mandrel	Blind Rivet	Solid Rivet
1	W710246-S900	BN	DP10-200/H	SA-0400/SA-0401	W708777-S900C	W790376-S900
2	W717186-S900	EN	DG11-220/H	SA-0400/SA-0402	W702554-S900C	W790377-S900
3	W708713-S900	AS	DZ09-025/H	SA-0400/SA-0401	W702512-S900C	W790376-S900

Figure 3

## 2017 Lincoln Continental Head Up Display (HUD) Calibration

As part of our ongoing effort to help repairers make the proper repair the first time, we continue our series of repairs straight from the official Ford Workshop Manual. This time, we look at the re-calibration for the Head Up Display on the 2017 Lincoln Continental, specifically warping compare, and service calibration reset. This procedure concludes a four-part series on HUD re-calibrations for the Continental (please refer to [2017 - Vol. 3](#), [2018 - Vol. 1](#) and [2018 - Vol. 2](#)).

Please note that the following illustrations are intended as a general guideline and are not all-inclusive. For more in-depth repair information on this and other Ford and Lincoln vehicles, consult the Ford Workshop Manual, which can be found at [Motorcraftservice.com](http://Motorcraftservice.com).

### Warping Compare

**(Section 419-03B: Collision Warning and Collision Avoidance System, General Procedures)**

### Special Tools / Equipment

- HUD Eye Box (Rotunda Part #501-417)
- Calibration Target (Rotunda Part #501-418)

1. With the brake pedal in the rest position, press and hold the OK button on the steering wheel, then press the Start button; release the OK button when the text "ETM" appears in the upper left-hand corner of the Head Up Display (HUD).

**NOTE:** If there are any warnings in the instrument cluster, the ETM inactive screen will appear in the windshield display. Press the OK button to clear each warning. If the OK button is pressed after all warnings are cleared, the HUD will exit ETM mode.

- The HUD should now display the entry screen for engineering test mode. Press OK to enter the test mode main screen or press Return to exit the test mode main screen.
- Position the driver-side and passenger-side sun visors so that they are facing the driver-side and passenger-side doors.
- Set up the calibration target outside of the vehicle, positioning it level and centered in the driver's view at the edge of the front bumper.
- Install the HUD eye box inside the vehicle. The HUD eye box should be placed on the dashboard directly behind the windshield (similar to how a sun visor would be placed).
- Select Warping Compare menu item and press OK.
- Using the up-and-down buttons, cycle through the available displays.

8. View and evaluate the supplier end-of-line calibration for warpage or return to distortional calibration and complete service calibration. **(Figure 1)**

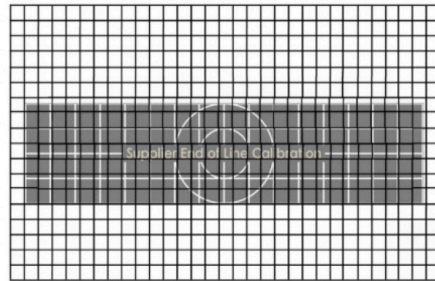

Figure 1

- Review the grid in the HUD image and compare it to the grid on the calibration target, switching between the different warping corrections. Use this method to confirm that the service warping distortion correction improves the image quality over the end-of-the-line warping.
- If the service calibration corrected the image distortion, exit the ETM and turn the vehicle off. If it did not correct the image distortion, carry out the service calibration reset procedure again, re-running all distortion correction steps.

### Service Calibration Reset

**NOTE:** This procedure is only to be used when the positional and distortional changes are to be erased and the HUD returned to the original factory settings.

- Press and hold the OK button; start the vehicle and release the HUD button when the text "ETM" appears in the upper left-hand corner of the HUD.

**NOTE:** If there are any warnings in the instrument cluster, the ETM inactive screen will appear in the windshield display. Press the OK button to clear each warning. If the OK button is pressed after all warnings are cleared, the HUD will exit ETM mode.

- The message center in the instrument cluster will display the entry screen to the engineering test mode. Press OK to enter the test mode or Return to exit.
- Select Reset Service Calibration menu item and press OK.
- To reset the service calibration to original factory settings, select YES and press OK. To retain the current calibration settings, select NO and press OK.
- Press Return; turn vehicle off and remove ETM visor.

**For additional questions, contact Ford Senior Damageability Engineer Gerry Bonanni at (313) 317-9000 or the Ford Crash Parts Hotline: [cphelp@fordcrashparts.com](mailto:cphelp@fordcrashparts.com)**

## Sikkens Helps Guarantee Improved Color Matching

When a vehicle arrives at the paint department, there's one goal: paint the vehicle only once. A poor color match means not only a redo, but also twice as much material, lower efficiency and higher paint and material numbers.

By working with car manufacturers, dealerships and other connections, Sikkens has been able to capture specific colors and tones. Each year, Sikkens collects more than 21,000 color measurements, as well as 10,000 panels of color. With this ever-growing collection of color, shops have access to the most up-to-date colors on the market.

### Color Tools

Building on the advanced digital tools Automatchic™ and MIXIT™ (see *On Target* - [2016, Vol. 3](#)), AkzoNobel offers a color tool portfolio that harnesses the power of digital color technology and will help shops achieve measurable improvements to their businesses, while delivering greater accuracy, greater efficiency and ultimately, greater profitability. When the digital tools are used together, the time and waste savings are significant.

For example, the digital search for Super White cuts time down by six minutes. "Six minutes here and there adds up," said Darlene Eilenberger, North American marketing manager of vehicle refinishes, AkzoNobel. "Rather than taking that time to visually search, the digital method will allow you to be more productive in your shop." Shops also use up to 20 percent less paint.

### Lowered Inventory Costs

By maintaining lower inventory costs, shops will enjoy lower overall business costs. "With the Sikkens system, any repair job can be completed with just 13 products, making it one of the lowest inventory-required systems in the industry," Eilenberger said.

### AUTOWAVE MM & AUTOBASE PLUS MM

Whether waterborne or solventborne, Sikkens basecoat technologies offer fast and accurate color match, excellent color coverage and metallic control, and spray-ability when used to duplicate OEM solid, metallic and pearl-color effects. Each basecoat offers versatility with the ability to convert solid colors to single stage, delivering a fast and easy solution with unrivaled color accuracy and hiding power.

### MANUAL PROPORTIONING UNIT

The manual proportioning unit (MPU) makes it possible to accurately measure any ready-to-spray clearcoat amount in the exact ratio of clear to hardener. A full cup can be mixed and ready to go in under five seconds.

For more information, visit [sikkensvr.com](http://sikkensvr.com).



## I-CAR® Announces Wide-Reaching Changes to Entire Core Curriculum

Following a nearly five-year process of gathering feedback about its education and recognition programs, I-CAR® (the Inter-Industry Conference on Auto Collision Repair) recently announced a variety of enhancements aimed at elevating industry

training standards and providing a more comprehensive, relevant and affordable solution to collision repair training programs, while making it easier for customers to interact with I-CAR.

Calling it a “complete refresh” of its entire roster of 263 core-curriculum courses, I-CAR plans to introduce its updated Automotive Collision Repair Industry Knowledge and Skills Protocol in the first quarter of 2019.

I-CAR says it will be more involved with repair shops, visiting annually to conduct ongoing assessments and advise on existing knowledge and skills gaps. In addition, I-CAR will increase the frequency of its Welding Training &

Certification™ skill reverification—moving from five years to three years—and it will no longer require a course repeat when the skill-set is reverified.

Additional details regarding the enhancements can be found on I-CAR's new website: [i-cartraintogain.com](http://i-cartraintogain.com).



# INSIDE THE INDUSTRY

## Legislation to Focus on OEM Procedures

The Automotive Service Association (ASA) and Alliance of Automobile Manufacturers have announced they'll work together in 2019 to pass state and federal legislation requiring the use of OEM repair procedures in collision repair. The initiative comes amid continued widespread complaints by repairers that they're often not properly compensated for following vehicle manufacturer procedures and after a failed bill in Indiana earlier this year would have allowed the use of generic “industry standards” as an acceptable alternative.

## “Opt-OE” Not Allowed in California

The California Bureau of Automotive Repair (BAR) has clarified its regulations to emphasize that ambiguous terms like “opt-OE” and “alt-OE” should not be used on collision repair estimates. The terms have been used more frequently in recent years, but pose a problem for shops and consumers since they are used to describe parts from a number of different sources. The BAR says parts are assumed to be OEM unless specifically identified “non-OEM,” and must be described as “new,” “used,” “rebuilt” or “reconditioned.”

## Recycled Rides Hits 1,800

The National Auto Body Council says its Recycled Rides program has now provided vehicles for 1,800 families since its inception in 2007. The group reached the milestone with the recent donation of vehicles to five military veterans in New Jersey. For more information, visit [NationalAutoBodyCouncil.org](http://NationalAutoBodyCouncil.org).

## VMT Hits New High

Motorists continue to pile up a record number of miles on U.S. roadways. The Federal Highway Administration estimates June's vehicle miles traveled (VMT) reached 269.2 billion—an increase of 0.9 percent from a year ago—pushing the 12-month rolling total for the month to a new high of 3.22 trillion miles.

## Highway Deaths and Deer Crashes Down Slightly

The National Safety Council estimates there were 18,720 deaths on U.S. roadways during the first six months of this year, a decline of 0.3 percent from the same period a year ago. At the same time, about 2.1 million people suffered serious crash-related injuries, about 1.0 percent fewer than the first half of 2017.

Meanwhile, State Farm's annual deer-vehicle collision study shows crashes with deer, elk, moose or caribou dipped to 1.33 million nationwide from July 1, 2017, to June 30 of this year, a drop of 0.7 percent from the previous year. West Virginia, Montana, Pennsylvania, Wisconsin and Iowa are the five states where such collisions are most likely to occur.

## GENUINE PARTING THOUGHTS

Have an idea? We'd love to hear from you. Your comments and article suggestions can be sent to: [cphelp@fordcrashparts.com](mailto:cphelp@fordcrashparts.com).

**On Target** can be downloaded free of charge from [FordCrashParts.com](http://FordCrashParts.com), or by clicking the Ford page on [OEMIStop.com](http://OEMIStop.com).

## ON TARGET

Scheduled to be published three times a year, **On Target** aims to provide Ford and Lincoln dealership parts departments and independent collision repair shops with the technical information needed to deliver efficient, high-quality repairs to Ford and Lincoln vehicle owners.

### Editor

Adam Gair

### Contributors

Chris Caris

Kim Jennings

Steven Lubinski

Andrea Presnell